

BDT13 – Differential type pressure gauge 100 & 160mm

Product description

Badotherm differential pressure gauge model BDT13 has a stainless steel diaphragm and one pointer to read the differential pressure. The variation in high static pressure makes this gauge suitable for almost all differential measurements. This pressure gauge is typically used for applications in the chemical, petro-chemical, oil & gas, power and utilities, machine building and general process industries.

Design standard

DIN 16003

Dial sizes, ranges & accuracy

Possibilities in ranges and accuracies are led by the dial size. Accuracy class is based on dry gauges. Liquid filling and add-on contact devices can affect the accuracy.

Dial size	Ranges	Accuracy
160mm	0...16 mbar to 0...60 mbar (flange 150mm)	1.6%
100mm	0...100 mbar to 0...25 bar (flange 100mm)	1.6%
160mm		

Mounting variation

All BDT13 gauges are bottom connection type A.

- **type A** (10) bottom connection, direct mounting
- **type C** (13) bottom connection, surface mounting (back)
- **type C2** (14) bottom connection, pipe mounting (back)

Materials of construction

	BDT13
Case	AISI 304 (optionally 316)
Bezel	
Connection ¹	AISI 316
Process cover flange	AISI 316
Sensing element ¹	AISI 316
Movement	Stainless steel
Pointer	Aluminium
Dial	
Window gasket	NBR
Fill plug	NBR (HNBR for filled gauges)
Flange gasket ¹	FKM
Window	Glass

¹ wetted materials



Process connection

Threaded version

Standard thread	optional
G ½ A	G ½, M20x1.5
½" NPT-m	½" NPT-f, R ½
¼ NPT – f	¼ NPT-m

Other thread standards such as ISO 7-1 R (BSPT), or DIN 13-1 (M20x1.5) can be selected as well.

-> See datasheet "thread information" for specific thread details

Pressure limitations

The gauge are built to withstand harsh environments however the DIN 16003 limits the use of a pressure gauge according below table.

Dial size	Steady	Fluctuating	Static pressure
100mm /160mm	FSV	0.9 x FSV	See overpressure table

FSV: full scale value

Static pressure table

range	standard	Optional
16 mbar	25 bar	-
25 mbar		
40 mbar		
60 mbar		
100 mbar	100 bar	200 bar
160 mbar		
250 mbar		
400 mbar		
600 mbar		
1.0 bar		
1.6 bar		
2.5 bar		
4.0 bar		
6.0 bar		
10 bar		
16 bar		
25 bar		

Temperature limitations

The gauges can withstand ambient and process temperature up to a certain limit. The limitations on temperature are:

	Ambient	Medium	Storage
Dry case	-20°C ...+60°C	-20°C...+200°C ¹	-40...+70°C
Filled case	-20°C ...+60°C	-20°C...+90°C	

1: only with FKM gasket selection

The variation of indication from the reference temperature (20°C) shall not exceed: $\pm 0.5\% / 10K$ FSV

Window

Standard BDT13 gauges have a glass window. Optionally it can be selected with laminated safety glass or plastic

Pointer

Standard pointer is a slotted black painted aluminum pointer and optionally with a micro adjustable pointer

Dial facing

The dial plate is made from aluminum and coated with UV resistant white coating. The black dial markings, scale, numbering, and interval is according the EN 837. Options like colored dial, customer logo, or colored segments are possible as well. Scale interval and numbering is following the EN837.

Degree of protection

The BDT13 has a standard degree of protection of IP65. The values are determined according the IEC/EN 60529.

Add-on contacts

The BDT13 can be equipped with an add-on contact mounted in a Makrolon hood. For low pressures <100 mbar inductive contacts are advised.

Case filling

Case filling for a BDT13 is only required to protect against corrosion of the aluminium parts or fogging inside the case. Case filling for ranges <100 mbar is not possible. As there is no sensing element inside the case that needs dampening the use of case filling is not required for that goal however the gauges can be filled with different kind of fill fluids. The fill fluids available are:

- BPF01 - Glycerine 86%
- BPF02 - Silicon
- BPF03 - Silicon for contacts
- BPF04 - Mineral oil (Foaming service)
- BPF05 - Halocarbon (inert fluid for oxygen service)

Special service

The gauges can be supplied cleaned for oxygen use. This means the gauge is assembled and tested in a special area free of oil. The gauges are individually packed in a plastic bag with marking. The symbol used is:



Certification & Declaration

Calibration

Gauges are full range calibrated as a factory standard. Optionally you can select a 5 points calibration certificate

[ATEX 114 - 2014/68/EU](#)

ATEX restrictions are explained in the IOM and in the ATEX background datasheet.

[EN 10204 material certificate](#)

A material 3.1 certificate on the wetted parts can be supplied.

Retaining bolts & nuts

The retaining bolts for the process cover flange depends on the static pressure range. Up to 100 bar M12 bolts are used. 200 bar static pressure is using M16 bolts. Most common materials are in the below table.

Grade bolt	Grade nut	Material
ISO 3506-1 A2-70	ISO 3506-2 A3	AISI 304
ISO 3506-1 A4-80	ISO 3506-2 A4	AISI 316
ASTM A192 B8M	ASTM A192 8M	AISI 316
ASTM A192 B7	ASTM A192 2H	Carbon steel
ASTM F468 F468W	ASTM F468 F467W	K500
Super Duplex	Super Duplex	S32760

Torque

The closing between upper part and lower part is done with retaining bolts. The torque of the M12 bolts is 55 Nm (40.5 ft-lb) and for the M16 bolts is 90Nm (55.3 ft-lb)

Gaskets

For the BDT13 a gasket is supplied for the closing between the upper and the lower part. The standard flange gasket is FKM (Viton) material. Depending on the chemical compatibility the option of NBR or EPDM

Material	Operating temperature
FKM ◀	-25 / +204°C
NBR	-40 / +108°C
EPDM	-55 / + 150°C

◀: Standard gasket

Mounting manifold or diaphragm seals

The BDT13 is most commonly used in combination with a manifold for easy testing and equalising. Advised valves for mounting to the BDT13 is the BDTM932 or the BDTM953.

Diaphragm seals can be mounted as well to the BDT13 however only a 81mm diaphragm is possible for the ranges ≥ 100 mbar and 89mm diaphragm for ranges < 100 mbar. Another aspect to keep in mind that mounting effect of the diaphragm seals cannot be zero adjusted on the BDT13. A levelled mounting (e.g. flow) is advised. Please contact Badotherm Sales department for the correct combination.

Wetted part and diaphragm combinations

For specific use the BDT13 can be made in several material combination. Basically the connection material, process cover, vent screw, and diaphragm are seen as wetted part metal parts. The closing gasket can be selected separately matching the process conditions. The most commonly used are marked with ◀ but all other combination are possible as well.

Flange + vent + connection Material	Diaphragm material		
	General name	UNS	Wst.
AISI 316(L) ◀	AISI 316L	S31603	1.4404
	Alloy C276	N27600	2.4810
AISI 304L	AISI 304L	S30400	1.4306
AISI 310 MoLn	25-22-2 LMN	S31050	1.4466
AISI 316 UG	AISI 316 UG	S31600	1.4435
AISI 321	AISI 321	S32100	1.4541
AISI 904(L)	AISI 904L	N08904	1.4539
Alloy 20	Alloy 20	N08020	2.4660
Alloy 400 ◀	Alloy 400	N04400	2.4360
Alloy 600	Alloy 600	N06600	2.4816
Alloy 625	Alloy 625	N06625	2.4856
Alloy 825	Alloy 825	N08825	2.4858
Alloy B2	Alloy B2	N10665	2.4617
Alloy C-22	Alloy C-22	N06022	2.4602
Alloy C-276 ◀	Alloy C-276	N10276	2.4810
Duplex F44	254 SMO (6Mo)	S31254	1.4547
Duplex F51/F60 ◀	Duplex 2205	S32205	1.4462
Duplex F53	Super Duplex 2507	S32750	1.4410
Duplex F55	Super Duplex 2507	S32750	1.4410
Nickel 201	Nickel 201	N02201	2.4068
Titanium Gr. 2	Titanium Gr. 1	R50250	2.7025
Zirconium 702	Zirconium 702	R60702	-

Dimensions table threaded

Type A (10)

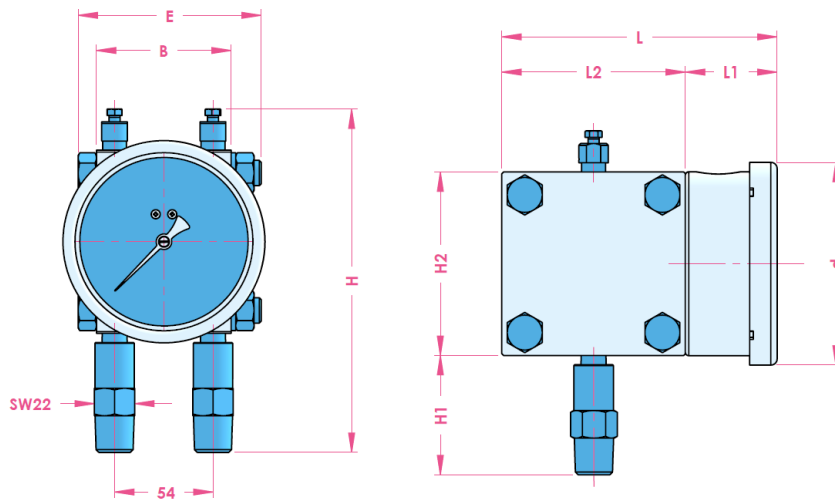

type	Range	Dial size	d	L	L1	L2	H	H1	H2	E	B	weight	filled
BDT13 (25 bar SP)	16...60mbar	160.0	160.0	202.0	52.0	150.0	236.0	65.0	150.0	100.0	73.6	11.2 kg	12.1 kg
BDT13 (100 bar SP)	≥100 mbar	100.0	110.0	150.0	50.0	100.0	186.0		100.0			6.4 kg	6.9 kg
		160.0	160.0	152.0	52.0				7.2 kg	8.3 kg			
BDT13 (200 bar SP)		100.0	110.0	150.0	50.0				100.0	9.6 kg	10.1 kg		
		160.0	160.0	152.0	52.0			140.0	113.6	10.4 kg	11.5 kg		

Type C

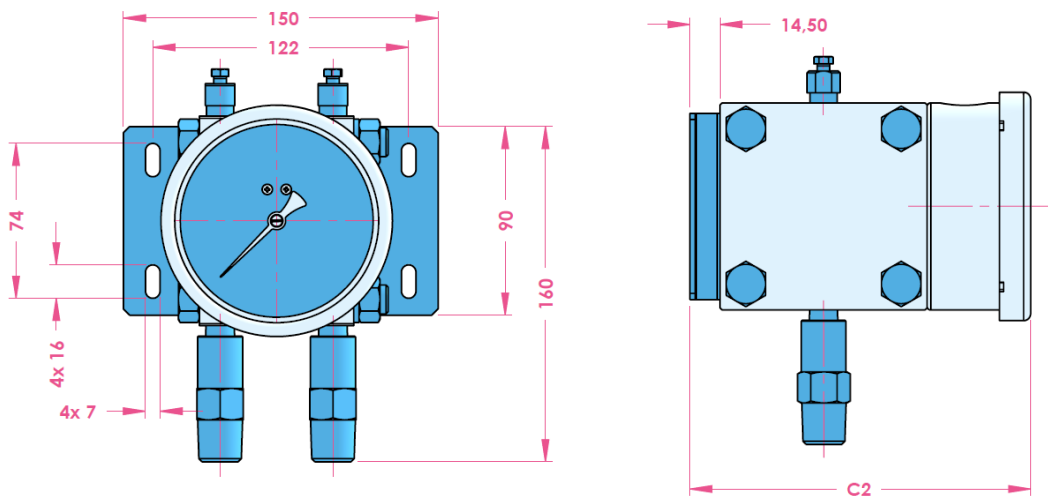

Type C2

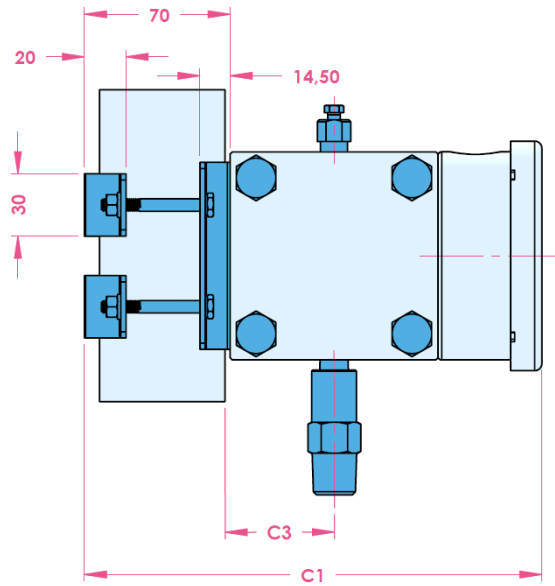
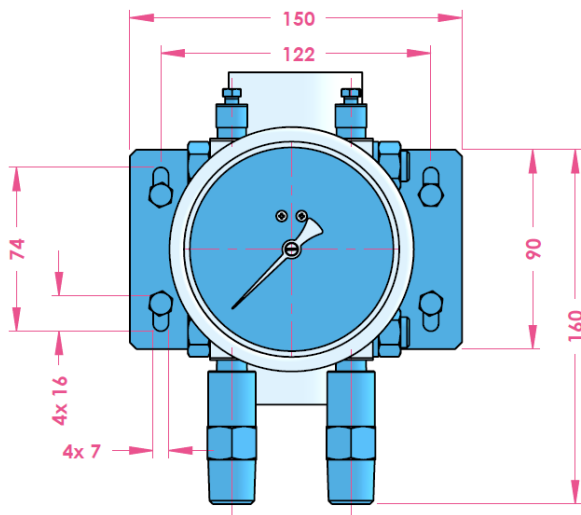

type	Range	Dial size	C1	C2	C3
BDT13 (25 bar SP)	16...60mbar	160.0	272.0	216.5	76.0
BDT13 (100 bar SP)	≥100 mbar	100.0	220.0	164.5	51.0
		160.0	222.0	166.5	
BDT13 (200 bar SP)		100.0	220.0	164.5	
		160.0	222.0	166.5	

Product code 100, 160mm

Code	
Example code:	BDT13 160 A G12M S303 S363 S304 A 0 G B36 16
BDT13 ◀	
BDT13-02	
TYPE	
100 mm ◀	100
160 mm ◀	160
MOUNTING	
Bottom connection - direct mounting (13) ◀	A
Bottom connection – wall mounting	C
Bottom connection – pipe mounting	C2
CONNECTION	
G1/2 ◀	G12M
1/2" NPT	N12M
R 1/2	R12M
M20 x 1.5	M20M
1/4" NPT-f	N14F
SENSING ELEMENT	
AISI 316L ◀	S363
Alloy 400	A400
Alloy C276	A276
Duplex 2205	2205
PROCESS FLANGES & CONNECTIONS	
AISI 316(L) ◀	S316
Alloy 400	A400
Alloy C276	A276
Duplex F51/F60	DF51
CASE/BEZEL MATERIAL	
AISI 304 ◀	S304
AISI 316L	S363
POINTER	
Adjustable slotted pointer ◀	A
Micro adjustable pointer	M
Add-on contact device (see table 4)	A__
LIQUID FILLING*1	
Dry ◀	0
BPF 01 - Glycerine filled 1,23 (86%)	1
BPF 02 - Silicone filled	2
BPF 03 – Silicone Contact use	3
WINDOW	
Glass ◀	G
Laminated safety glass	L
Acrylic (SAN)	A
RANGE	
See page table 1 and table 2
ACCURACY	
1,6 ² ◀	16

◀: is the sign for the standard pressure gauge.

1: Not in combination with span <100 mbar

2: accuracy is without the addition of fill fluid or contact device.

Tabel 1: Pressure Range code

bar		mbar		psi		kPa		kgf/cm ²	
Code	Range	Code	Range	Code	Range	Code	Range	Code	Range
B31	0...0,6	M19◀	0...16	P32	0...15	L31	0...60	K31	0...0,6
B35	0...1	M20◀	0...25	P35	0...25	L35	0...100	K35	0...1
B36	0...1,6	M21◀	0...40	P37	0...35	L36	0...160	K36	0...1,6
B38	0...2,5	M22◀	0...60	P40	0...60	L38	0...250	K38	0...2,5
B40	0...4	M24	0...100	P43	0...100	L40	0...400	K40	0...4
B42	0...6	M25	0...160	P46	0...150	L42	0...600	K42	0...6
B45	0...10	M27	0...250	P48	0...250	L45	0...1000	K45	0...10
B50	0...16	M29	0...400	P51	0...350			K50	0...16
B54	0...25	M31	0...600					K54	0...25
		M35	0...1000						

◀ not possible with the BDT13-02

Table 2: Secondary scale

Dual scale option	code
PSI red	#PR
PSI black	#PB
PSI blue	#PBL
bar red	#BR
bar black	#BB
bar blue	#BBL

Add the code behind the pressure code
(e.g. B45#PR for 0...10 bar/psi with red scale)

Table 3: General option code

Option (start options with X_)	code
Cleaned for Oxygen use	_CFO
NACE ISO 15156 (MR 01 75)	_N75
ATEX II 2G Ex h IIC	_ATEX
3.1 material certificate	_IC31
Calibration certificate 5 points ¹	_CC5
Adjusting key for contact	_AKC
Lead cable + Adjusting key for contact	_LCK

1: excluding contact device and case filling

Table 4: Contact option code

Option (start options with X_)	code	
Snap-action magnetic contact*	M1 (make contact)	_AM1
	M2 (break contact)	_AM2
	M11 (make - make contact)	_AM11
	M12 (make - break contact)	_AM12
	M21 (break - make contact)	_AM21
	M22 (break - break contact)	_AM22
Inductive contact	I1 (make contact)	_AI1
	I2 (break contact)	_AI2
	I11 (make - make contact)	_AI11
	I12 (make - break contact)	_AI12
	I21 (break - make contact)	_AI21
	I22 (break - break contact)	_AI22

<100 mbar only Inductive contact possible. Accuracy BDT13 is excluding contact
Contacts are without cable and adjusting key.

Table 5: Gasket option code

Option	code
NBR	NB
EPDM	EP

Table 6: Bolting option code

Option	code
ISO 3506-1 A4-80	A480
ASTM A192 B8M	SB8M
ASTM A192 B7	SB7
ASTM F468 Alloy K500	B500
Super Duplex	BSDX

Change log

Date	Change
22-4-2020	Table header static pressure changed from “overpressure” to “static pressure”
2-6-2020	Coding tables adjusted with more options and removed ranges from ranges table
6-4-2021	Temperature limits FKM and Viton changed.
21-6-2021	Code case material updated
6-12-2021	Updated information in the accuracy text block

PG 7004 – 6th of December 2021

Holland – Romania – India – Thailand – Dubai – USA

To our knowledge, the information contained herein is accurate as of the date of this document. However neither Badotherm, nor its affiliates makes any warranty, express or limited, or accepts any liability in connection with this information or its use. This information is for technical skilled persons at their own discretion and risk and does not relate to the use of this product in combination with any other product. The user alone finally determines suitability of any information or material in contemplated use, the manner of use and whether any patents are infringed. This information gives typical properties only. Badotherm reserves the right to make changes to the specifications any materials without prior notice. The latest version of the datasheet can be found on www.badotherm.com.

© 2015 Badotherm, all rights reserved. Trademarks and/or other products referenced herein are either trademarks or registered trademarks of Badotherm.